

A Design for Elevator Group Controller of Building Using Adaptive Dual Fuzzy Algorithm

Hun-Mo Kim*

Professor, School of Mechanical engineering, Sungkyunkwan University, 300 Chunchun-dong, Jangan-ku, Suwon, Kyunggi-do 440-746, Korea

In this paper, the development of a new group controller for high-speed elevators is described utilizing the approach of adaptive dual fuzzy logic. Some goals of the control are to minimize the waiting time, mean-waiting time and long-waiting time in a building. When a new hall call is generated, an adaptive dual fuzzy controller evaluates the traffic patterns and changes the membership function of a fuzzy rule base appropriately. A control algorithm is essential to control the cooperation of multiple elevators in a group and the most critical control function in the group controller is an effective and proper hall call assignment of the elevators. The group elevator system utilizing adaptive dual fuzzy control clearly performs more effectively than previous group controllers.

Key Words : Elevator, Group Control, Fuzzy Logic, Adaptive Dual Fuzzy Control

1. Introduction

As buildings get higher and bigger, elevators become faster and more people have to move from one building to another, group control is crucial in controlling multiple elevators at the same time for the convenience of users. In this paper, we will demonstrate how its performance can be improved by improving the previous control logic of the elevator system.

In the initial elevator group control, the system is functioned by using the simple traffic pattern which is normal, Down-peak, and Up-peak. The previous group control was carried out according to the waiting time of each hall call using a microprocessor (Cho, Y. C., Gagov, Z., and Kwon, W. H., 1999). T. Tobita (Tobita, T., Fujino, A., Inaba, H., Yoneda, K., and Ueshinma, T., 1991) used this method, but the

group control methods using fixed evaluating factors can not evaluate complementary control goals totally because only one control goal is minimized. The traffic demand in a high-rise building is mostly from bottom to top or the opposite pattern. Studies have also been reported to simplify the problems of the group control system for these specific traffic demands. D. L. Pepyre (Pepyne, D. L. and Cassandras, C. G., 1996; Pepyne, D. L. and Cassandras, C. G., 1997; Pepyne, D. L. and Cassandras, C. G., 1998) has studied Up-peak traffic pattern in detail.

W. L. Chan (Chan, L. W. and So, A. T. P., 1995; Chan, L. W. and So, A. T. P., 1997; So, A. T. P., Yu, J. K. L., and Chan, W. L., 1999) proposed the dynamic zoning method which dynamically changes the zone allocated to an elevator in accordance with the change in traffic demand. This zoning or dynamic zoning method is essential during rush hour in a high-rise building, but it could be less effective in a medium-size building. Also, it cannot be used in a building where many people move from one floor to another like many department stores.

A. F. Alani (Alani, F. A., Mehta, P., Stonham, J., and Prowse, R., 1995) did exhaustive research

E-mail : kimhm@me.skku.ac.kr

TEL : +82-31-290-7500; **FAX :** +82-31-290-7507

Professor, School of Mechanical engineering, Sungkyunkwan University, 300 Chunchun-dong, Jangan-ku, Suwon, Kyunggi-do 440-746, Korea. (Manuscript Received April 10, 2001; Revised August 9, 2001)

to find every possible way of reducing the overall traveling time of passengers. B. A. Powell (Powell, A. B., 1992) developed the channeling method to control rush hour traffic and lunch time traffic. Channeling is an attempt to serve users who have the same destination with one elevator by reducing the number of high floors in service. This concept has been developed with regard to both office opening hours and closing hours.

The present method of elevator group control mainly uses artificial intelligence (So, A. T. P., Yu, J. K. L., and Chan, W. L., 1999) such as neural networks or fuzzy logic (Kaneko, M., Ishikawa, T., and Sogawa, Y., 1998; Bum, K. C. and Bac, Y. L., 1995; Gudwin, R., Gomide, F., and Andrade Netto, M., 1998). Group control using a neural network (Zhu, D., Li, J., Zhou, Y., Guanghui, S., and Kai, H., 1997) is made to adapt to new conditions through the transmission of continuous learning and input data.

M. Amano (Amano, M., Yamajaki, M., and Ikejima, H., 1995) recognized traffic patterns using a neural network and used it for the assignment of hall calls. In other logical studies, A. T. P. So (So, A. T. P., Beebe, J. R., Chan, L. W., and Liu, K. S., 1995) used the neural network technology to recognize five traffic patterns (Up-peak, Down-peak, Off-peak, One-way, and Two-way). These methods using a neural network can not be operated on-line, but they can be operated in off-line. Also, they require a lot of learning data and cannot learn every possible situation.

It was Mitsubishi Corporation that first applied fuzzy logic to elevator systems (Umeda, Y., Uetani, K., Ujihara, H., and Tsuji, S., 1989). Whenever people want to board an elevator, an appropriate rule is chosen by the if-then rule. The reason why the fuzzy rule was applied to elevator group control was due to the uncertainty of the elevator system. The advantage of this kind of group control using the fuzzy rule is that an expert decides the rule of the control, and the rule of the control is fixed when it is installed. The group controller can easily manage the uncertainty and the nonlinearity of an elevator with the help of the experience of an expert. But the

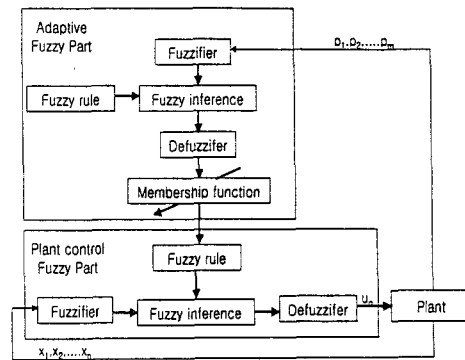

Fig. 1 Adaptive dual fuzzy controller

disadvantages of fuzzy rule include the difficulty of regulating fuzzy membership functions and the need for great efforts to develop and make new rules.

In this paper, we used fuzzy logic to satisfy the various control goals and we proposed an adaptive dual fuzzy controller to solve the problem of fixing a rule base. Also, we evaluated the performance of the group controller under the various traffic conditions using an elevator experiment device.

2. Adaptive Dual Fuzzy Control Theory

A fuzzy controller can be used generally in the processing of uncertain or unreliable data when it is input from a known system, that is, from a predictable system. But in unpredictable situations or when there are parameters which affect the input variable, it is difficult to use a general fuzzy controller. These systems need a mechanism to change the rule base as the conditions change.

2.1 Adaptive dual fuzzy controller

Figure 1 shows the structure of an adaptive dual fuzzy controller. The adaptive dual fuzzy controller consists of a plant control fuzzy part and an adaptive fuzzy part to change the coefficients of the membership function.

Assuming that the state input of the system for a fuzzy control part is x_1, x_2, \dots, x_n and the output

is u . The parameters which affect the input variables are p_1, p_2, \dots, p_m .

The direct method devised by Mamdani is used as the inference method in this case. The rule base of a plant control fuzzy part is given below:

R1) If x_1 is A_1 and x_2 is B_1 and \dots and x_n is N_1 then u is U_1

If x_1 is A_2 and x_2 is B_2 and \dots and x_n is N_2 then u is U_2

\vdots

If x_1 is A_n and x_2 is B_n and \dots and x_n is N_n then u is U_n (1)

And the rule base of the adaptive fuzzy part is as follows:

R2-1) If p_1 is P_1 and p_2 is Q_1 and \dots and p_m is S_1 then θ_1 is V_{11}

If p_1 is P_2 and p_2 is Q_2 and \dots and p_m is S_2 then θ_1 is V_{21}

\vdots

If p_1 is P_z and p_2 is B_z and \dots and p_m is N_z then θ_1 is V_{z1}

R2-L) If p_1 is P_1 and p_2 is Q_1 and \dots and p_m is S_1 then θ_L is V_{1L}

If p_1 is P_2 and p_2 is Q_2 and \dots and p_m is S_2 then θ_L is V_{2L}

\vdots

If p_1 is P_z and p_2 is B_z and \dots and p_m is N_z then θ_L is V_{zL} . (2)

R2 includes the rule base for $\theta_2, \dots, \theta_{L-1}$.

According to the above rule base, A, B, N, U, P, Q, S, V are all fuzzy sets and θ is the center value of fuzzy set U. If a definite value, x_1', x_2', \dots, x_n' and p_1', p_2', \dots, p_m' , from the plant is input into the adaptive dual fuzzy controller, output u_0 can be defined in the following way:

$$\begin{aligned} \phi_1 &= \mu_{P_1}(\phi_1') \wedge \mu_{Q_1}(\phi_2') \wedge \dots \wedge \mu_{S_1}(\phi_m') \\ \phi_2 &= \mu_{P_2}(\phi_1') \wedge \mu_{Q_2}(\phi_2') \wedge \dots \wedge \mu_{S_2}(\phi_m') \\ &\vdots \\ \phi_z &= \mu_{P_z}(\phi_1') \wedge \mu_{Q_z}(\phi_2') \wedge \dots \wedge \mu_{S_z}(\phi_m') \end{aligned} \quad (3)$$

Thus, the inference result of the rule base R2-1 is as follows:

$$\begin{aligned} \mu_{V_{11}}(\theta_1) &= \phi_1 \wedge \mu_{V_{11}}(\theta_1) \\ \mu_{V_{21}}(\theta_1) &= \phi_2 \wedge \mu_{V_{21}}(\theta_1) \\ &\vdots \end{aligned}$$

$$\mu_{V_{z1}}(\theta_1) = \phi_z \wedge \mu_{V_{z1}}(\theta_1) \quad (4)$$

and the final inference result is given below:

$$\mu_{V_1}(\theta_1) = \mu_{V_{11}}(\theta_1) \vee \mu_{V_{21}}(\theta_1) \vee \dots \vee \mu_{V_{z1}}(\theta_1) \quad (5)$$

Using the same method, if you apply to $\theta_2, \dots, \theta_L$,

$$\mu_{V_2}(\theta_2) = \mu_{V_{12}}(\theta_2) \vee \mu_{V_{22}}(\theta_2) \vee \dots \vee \mu_{V_{z2}}(\theta_2)$$

$$\mu_{V_3}(\theta_3) = \mu_{V_{13}}(\theta_3) \vee \mu_{V_{23}}(\theta_3) \vee \dots \vee \mu_{V_{z3}}(\theta_3)$$

\vdots

$$\mu_{V_l}(\theta_l) = \mu_{V_{1l}}(\theta_l) \vee \mu_{V_{2l}}(\theta_l) \vee \dots \vee \mu_{V_{zl}}(\theta_l). \quad (6)$$

A defuzzifier using the center of gravity method is as defined below:

$$\theta_{1o} = \frac{\int \mu_{V_1}(y) y dy}{\int \mu_{V_1}(y) dy}$$

$$\theta_{2o} = \frac{\int \mu_{V_2}(y) y dy}{\int \mu_{V_2}(y) dy}$$

\vdots

$$\theta_{lo} = \frac{\int \mu_{V_l}(y) y dy}{\int \mu_{V_l}(y) dy} \quad (7)$$

If these values are applied to the plant fuzzy part, the membership function of the plant control fuzzy part U_1, U_2, \dots, U_n changes to $\tilde{u}_1, \tilde{u}_2, \dots, \tilde{u}_n$, we define the final output value u_0 in the following way:

$$\mu_{\tilde{u}_1}(u) = \mu_{A_1}(x_1 \wedge \mu_{B_1}(x_2 \wedge \dots \wedge \mu_{N_1}(x_n) \wedge \mu_{\tilde{u}})_1(u)$$

$$\mu_{\tilde{u}_2}(u) = \mu_{A_2}(x_1 \wedge \mu_{B_2}(x_2 \wedge \dots \wedge \mu_{N_2}(x_n) \wedge \mu_{\tilde{u}})_2(u)$$

\vdots

$$\mu_{\tilde{u}_n}(u) = \mu_{A_n}(x_1 \wedge \mu_{B_n}(x_2 \wedge \dots \wedge \mu_{N_n}(x_n) \wedge \mu_{\tilde{u}})_n(u) \quad (8)$$

$$\mu_{\tilde{u}}(u) = \mu_{\tilde{u}_1}(u) \vee \mu_{\tilde{u}_2}(u) \vee \dots \vee \mu_{\tilde{u}_n}(u) \quad (9)$$

$$u_0 = \frac{\int u \mu_{\tilde{u}}(y) y dy}{\int \mu_{\tilde{u}}(y) dy} \quad (10)$$

3. System Configuration

Figure 2 shows the configuration of the elevator group control system.

The group controller gets the information necessary for operation from each car controller and then allocates a hall call to the optimal elevator satisfying the evaluation goal. A hall call is a call which registers the intention of a passenger to use the elevator. There are two kinds of call: Up-Hall Call, and Down-Hall Call.

A monitoring system displays the current state of the elevator from the state data, and also gathers and saves all kinds of operation data. In

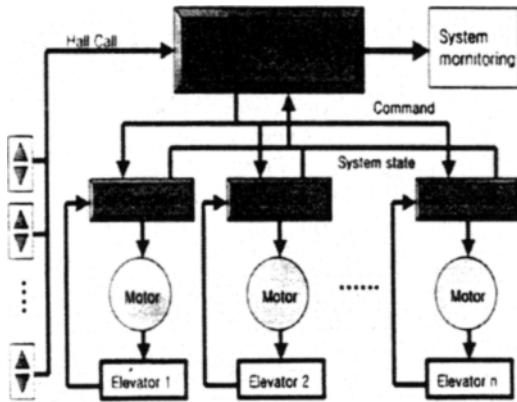

Fig. 2 System configuration

In addition to the described functions, the monitoring system supplies a control format by transmitting the requests of the operator to the group controller.

The car controller, as the real part operation elevator, controls the start, acceleration, deceleration, stop and door open/close functions, and transmits the state information of the elevator which decides on operation to the group controller. The group controller decides the optimal allocation car and transmits the state data to the monitoring system. The optimal allocation is registered by the state data transmitted from the car controller and the requests of the operator transmitted from the monitoring system.

3.1 System modeling

3.1.1 The state information of a group control system

Elevator systems have to know the state information of the system in order to make accurate system modeling. The state information is the data forecasting the next action of the system by describing the current state of the system. State information is generally classified into observable and non-observable.

For example, the floor where an elevator stays is the observable data and the number of passengers inside an elevator is the non-observable data. Therefore, the observable data is the only state information used for making group

Table 1 System information of a elevator system

Item	Symbol	Observability
Present Floor	F_1	O
Direction of Car	D_1	O
Car Call Set	C_{is}	O
Hall Call Set	H_{is}	O
Speed of Car	V	O
Weight Excess	L_1	O

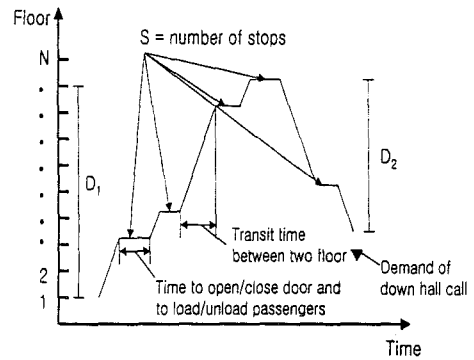

Fig. 3 Parameter on hall call response time

control systems. Table 1 shows the observable data of an elevator system.

3.1.2 Hall call response time : T_r

To calculate the hall call response time (T_r) accurately, the model must be made with consideration given to all the state information of the elevator.

The actual T_r may be longer or shorter than the estimated value if there is a cancellation request, another input call, an existing car call, an allocation hall call, position of the elevator or any actions which affect the speed or direction of the elevator.

Figure 3 shows the parameters which are needed for the calculation of the hall call response time.

When calculating T_r , a preferentially considered problem is the moving distance ($D = D_1 + D_2$) to the floor from which the hall call comes, and the stop count (S) which is experienced while moving to a hall call. Also, as well as D , S , the delayed time caused by the passengers and the opening and the shutting time of the elevator door must be considered.

$$D = (F_n - F_i) \cdot x \tag{11}$$

$$S = C_{is} - H_{is} - (C_{is} \cap H_{is}) \tag{12}$$

$$T_s = T_d + P_i \cdot T_{pi} + P_o \cdot T_{pu} \tag{13}$$

Where, F_n is the new floor where the hall call has occurred, F_i is the current floor of the elevator, x is the floor to floor distance, C_{is} is the car call number of car n and H_{is} is the hall call number of car n . T_s is the delay time when an elevator stop occurs. T_d is the opening and shutting time of the elevator door. T_{pi} is the time it takes for one passenger to get on the elevator. T_{pu} is the time it takes for one passenger to get off the elevator. P_i is the number of passengers who get on the elevator, and P_o is number of passengers who get off the elevator.

The hall call response time is calculated in accordance with the upper parameters. The results are as follows, and the value given is the time to the new hall call.

$$T_r(e) = \frac{(F_n - F_i) \cdot x}{V} + S \cdot (T_d + P_i \cdot T_{pi} + P_o \cdot T_{pu}) \tag{14}$$

In this study, the mean waiting time (T_m) to do the group control, which does the work of each elevator uniformly, and the long waiting time (T_l) are selected as evaluation goals to evaluate the allocation of elevators.

3.1.3 A pattern decision of traffic state

This method suitably changes the rule base and allocates an optimal elevator according to the traffic pattern (Up-peak traffic, Down-peak traffic, or Normal traffic). Thus, in this paper, we present a method of mutating the degree of the traffic pattern whenever a call is generated. As these values changed, the fuzzy rule base is adapted.

Generally, in a building the pattern of Up-peak traffic is different from that of Down-peak traffic. Up-peak traffic is mainly generated around office arrival hours. After an Up-hall call is generated at a base floor (mainly the 1st floor), the car calls of all floors are generated. While the Down-peak traffic is mainly generated at lunch time and closing hours. After the Down-hall calls of all floors are generated, the car call of the base floor is generated. As a result, calculations of the two

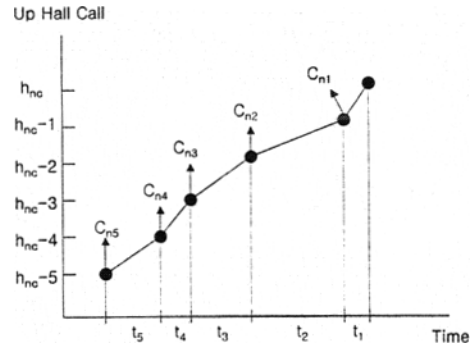

Fig. 4 Variable of traffic pattern

kinds of traffic differ.

The important data for calculating the degree of Up-peak traffic are the time intervals to show how often hall calls are generated from the former Up-hall calls when a new Up-hall call is generated and the number of car calls from the previous hall call. A large number of car calls appear to show that many people want service.

Figure 4 shows data to calculate the degree of Up-peak when a new Up-hall call (h_{nc}) is generated.

When the time interval between a new Up-hall call and the previous hall call is small and there are many car calls, we can define that as Up-peak traffic. The data just short of generating of a new hall call is most important, old data has less weight. The formula for this is as follows:

$$U_p = \sum_{p=1}^5 \alpha_p \frac{C_{np}}{t_p} \tag{15}$$

Where, U_p is the evaluation value of Up-peak, α_p is the weight factor, C_{np} is the number of car calls for h_{nc} -pth hall call. If a car call is not generated due to not being serviced for Up-hall call of h_{nc} , then $C_{np}=1$ for the car calls that will come in next. t_p is the time interval of each hall call. $\alpha_p = (6-p)^2$, because the data just short of h_{nc} is the most important, old data has less weight.

In contrast to the Up-peak traffic, in Down-peak traffic a Down-hall call is simultaneously generated at many floors for a short time. Thus, we need to add a number of old data. The formula of Down-peak traffic is as follows:

$$D_p = \sum_{p=1}^{15} \alpha_p \frac{C_{np}}{t_p} \quad (16)$$

$$L_t = \frac{lt}{2}$$

In contrast to the Up-peak traffic, the α_p of $h_{nc}-1$ is almost the same as that of $h_{nc}-2$ because a hall call is simultaneously generated at many floors for a short time. Thus, we define it as follows:

$$\alpha_1 = \alpha_2 = \alpha_3 = 5, \alpha_4 = \alpha_5 = \alpha_6 = 4, \alpha_7 = \alpha_8 = \alpha_9 = 3$$

$$\alpha_{10} = \alpha_{11} = \alpha_{12} = 2, \alpha_{13} = \alpha_{14} = \alpha_{15} = 1 \quad (17)$$

We define normal traffic as being the value of Up-peak and Down-peak below a specific value.

3.1.4 Reassignment algorithm

When a new hall call is generated, the group controller gathers the present state information of the elevator from the car controller and allocates the optimal elevator. But this hall call can change to an inefficient allocation because of the generating of a car call by the allocated hall call, the accumulation of allocations of new hall calls, and the uncertain action of the passengers. Thus, this allocation error which appears as a state change needs to be reassigned at some given moment. Then the performance of the elevator system will improve.

In this paper, focusing on real time and efficiency, we set a limit time (L_t) and reassigned a hall call to reach this value.

We propose the following method to select L_t .

L_t can be changed according to the number of floors in a building and the speed of the elevator. When v represents the speed of the elevator, f represents the floor number of the building, h represents the height from floor to floor, and t represents a long waiting time, we can calculate the long waiting time as follows,

$$lt = \frac{2 \cdot f \cdot h}{v}$$

When reassignment is generated below this time, there is a possibility that hall calls may be excessive. This possibility increases if the reassignment time is too late or too fast, or if the efficiency is low. Thus, in this paper, we set the proper reassignment time as follows,

The calculation procedure of the reassignment is as follows:

1. Check time of a hall call (HCT: Hall Call Time)
2. Check that the hall call time is equal to L_t
3. If HCT is equal to L_t , allocate an elevator to stop at the floor from where hall call was generated
4. If there is no elevator to stop at the floor, the group controller gathers the state information from the elevators
5. Calculate the T_r of each elevator
6. Calculate $T_r(0) < T_r(i)$
7. Reassign the elevator to have the smallest T_r value

4. Design of Adaptive Dual Fuzzy Controller

In this paper, the waiting time (T_r), mean waiting time (T_m), and long waiting time (T_1) are the evaluating measures.

After the group controller calculates the values of each elevator car, it allocates the elevator car with the highest value. For this, the fuzzy rule base is as follows.

A linguistic variable of the fuzzy controller is given below:

- T_r : Waiting Time
- T_m : Mean Waiting Time
- T_1 : Long Waiting Time
- VL : Very Long LG : Long MD : Middle
- SH : Short VS : Very Short
- Ψ_1 : Priority1 Ψ_2 : Priority2
- VB : Very Big BG : Big MD : Middle
- SM : Small VS : Very Small

We represent two fuzzy rule bases which can be used to allocate the optimal elevator as given below:

- rule 1) If T_r is VB and T_m is BG then Ψ_1 is VS
- rule 2) If T_r is VB and T_1 is BG then Ψ_2 is VS

Table 2 Rule base for Ψ_1

$T_r \backslash T_m$	VL	LG	MD	SH	VS
VL	VS	VS	SM	SM	SM
LG	VS	SM	SM	MD	MD
MD	SM	MD	MD	MD	BG
SH	MD	MD	BG	BG	VB
VS	MD	BG	BG	VB	VB

Table 3 Rule base for Ψ_2

$T_r \backslash T_1$	VL	LG	MD	SH	VS
VL	VS	VS	VS	VS	VS
LG	VS	SM	SM	SM	SM
MD	VS	SM	MD	MD	BG
SH	SM	MD	BG	BG	VB
VS	MD	BG	BG	VB	VB

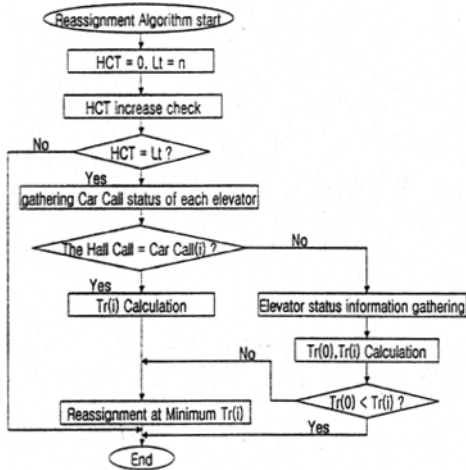

Fig. 5 The flow chart of reassignment algorithm

In this paper, we have twenty-five rule bases that represent the priority of each car with reference to the waiting time (T_r) and the mean waiting time (T_m) and twenty-five rule bases that represent the priority of each car with reference to the waiting time (T_r) and the long waiting time (T_1).

Tables 2 and 3 show these rule bases.

The priorities 1 and 2 are calculated by a fuzzy inference engine from these rule bases, and the

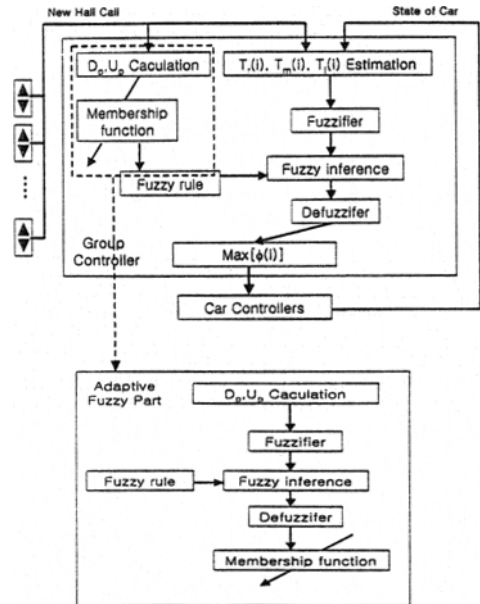

Fig. 6 Block diagram of the elevator group control system

evaluation value (Φ) of each car is calculated. The car that has the highest value of all the elevator cars is the final allocation car (U).

$$\Phi(i) = \Psi_1(i) + \Psi_2(i) + \lambda(i) \quad (18)$$

$$U = \text{Max}[\Phi(i)]. \quad (19)$$

The λ is the weight factor used to increase the possibility of selecting i -th elevator when a new hall call is generated on the floor where the i -th elevator is going to stop. Also, the weight increases when a new hall call is generated at the nearest floor to the car call. Figure 6 shows a block diagram of the elevator group control system using an adaptive dual fuzzy controller.

5. Simulation Result

In this paper, we have developed a graphic simulator to evaluate the performance of the adaptive dual fuzzy controller and we have compared it with the previous controller. Figure 7 shows a graphic simulator of an elevator group control system.

As it is necessary to compare hall calls and car

Table 4 A system characteristic

A use of building	Office
Floors	Floor 7
Number of elevator	3
Height of floor	8cm
Speed of elevator	0.96 m/min

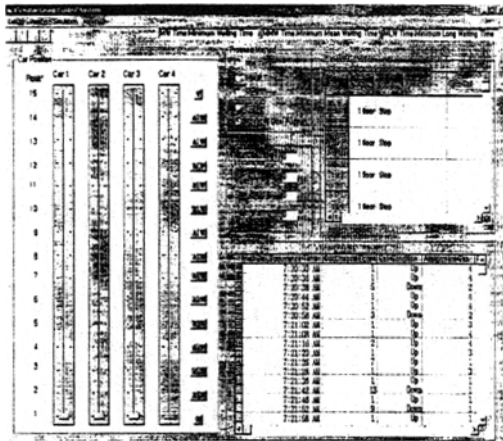

Fig. 7 The display of graphic simulator

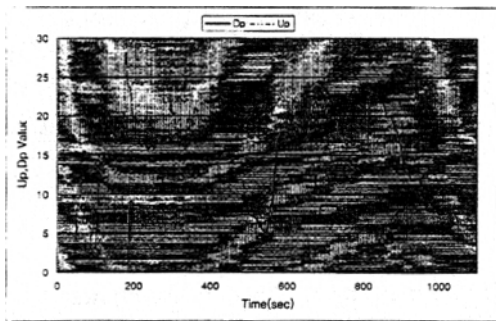

Fig. 8 Data of traffic pattern

calls with the previous operation system, we carried out experiments by storing voluntary datum for 15~20 minutes and responding to this datum during the appointed time. We set the turns of generating call datum. First, normal traffic occurs and then Up-peak traffic occurs slowly for 5 minutes. This is followed by normal traffic and then Down-peak traffic occurs for 5 minutes. Figure 8 shows the values of Up-peak and Down-peak in the generating datum. Table 4 shows the initial setting of the whole system.

In this paper, we compared the control style of

Table 5 A simulation result

	Number of long time	Total waiting time	Mean waiting time
Minimum waiting time method	15	4401s	27.54s
Minimum mean waiting time method	10	4126s	25.7s
Minimum long waiting time method	12	4236s	26.4s
Fuzzy method	7	3806s	23.7s
Adaptive Dual Fuzzy method	5	3516s	21.9s

Table 6 The generation number of long waiting during up-peak traffic(simulation)

	Above 100s	Above 80s	Above 60s	Total
Minimum waiting time method	0	0	1	1
Minimum mean waiting time method	0	0	1	1
Minimum long waiting time method	0	0	2	2
Fuzzy method	0	0	1	1
Adaptive Dual Fuzzy method	0	0	0	0

each group using the long waiting and mean responding time for the hall calls because they are used as efficiency measures in normal operations.

The results of the simulation appear in Table 5. For long wait generation, the minimum long waiting time method shows better results than the previous controller, and the fuzzy controller shows even better results. The adaptive dual fuzzy controller proposed in this paper appears to provide the best result, because the group controller appropriately allocated the elevator in all the traffic patterns.

Tables 6 and 7 show each generating number of long waits in Up-peak and Down-peak. As seen in Fig. 9, using the adaptive dual fuzzy method long waits occasionally appear more than in the other methods. This is similar for Down-peak traffic. Also, the fuzzy controller is similar to the adaptive dual fuzzy controller for Down-peak.

Table 7 The generation number of long waiting during down-peak traffic(simulation)

	Above 100s	Above 80s	Above 60s	Total
Minimum waiting time method	1	5	5	11
Minimum mean waiting time method	0	3	5	9
Minimum long waiting time method	0	1	7	8
Fuzzy method	0	1	5	6
Adaptive Dual Fuzzy method	0	0	4	4

Table 8 A experiment result

	Number of long time	Total waiting time	Mean waiting time
Minimum waiting time method	19	5024s	31.4s
Minimum mean waiting time method	8	3143s	19.6s
Minimum long waiting time method	8	3836s	23.9s
Fuzzy method	7	2993s	18.7s
Adaptive Dual Fuzzy method	4	2854s	17.8s

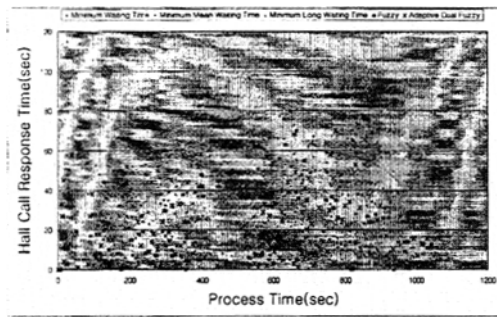

Fig. 9 The distribution of hall call waiting time

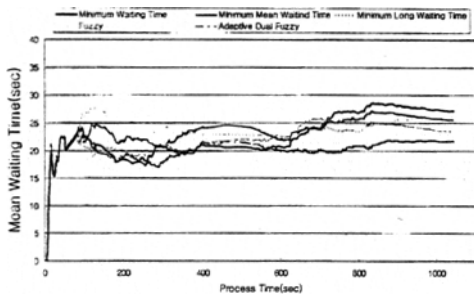

Fig. 10 The mean-waiting time transition on hall call

For mean-waiting time, as shown in Fig. 10, the adaptive dual fuzzy controller shows the best result of all the controllers. The minimum mean waiting time method shows a good result for Up-peak, but suddenly begins to increase for Down-peak traffic. The other group controller shows that the mean waiting time rapidly increases in Up-peak, and gradually settles down in Down-peak, while the adaptive dual fuzzy controller



Fig. 11 An elevator group operation

shows that the mean waiting time settles down in all traffic patterns. This result means that the waiting time of the passengers is reduced during Up-peak and Down-peak traffic.

To summarize the above simulation results, the previous group controller showed a good result in unique traffic patterns or unique control goals, but the adaptive dual fuzzy controller adapted well to changes in traffic patterns, considering various control goals.

6. Experiment Result

In this paper, we carried out experiments using a model elevator experiment device to prove the proposed effectiveness of the adaptive dual fuzzy algorithm. Figure 11 shows the working elevator experiment device.

In this experiment, we set 30 seconds for L_T under the conditions of reassignment and compared the previous algorithm with the proposed adaptive dual fuzzy algorithm. The

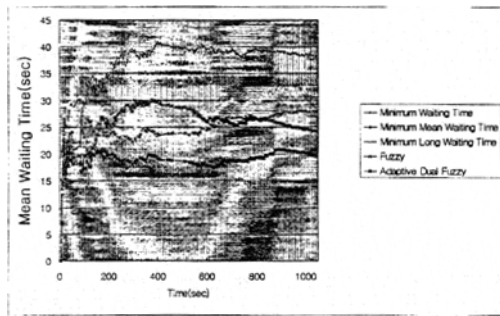

Fig. 12 The mean-waiting time transition on hall call

results are given in Table 8.

As seen using the minimum waiting time method, the minimum mean waiting time and the minimum long waiting time, the long waiting time generating number is shown best using the minimum long waiting time method, and the mean waiting time is best shown using the minimum mean waiting time method. The fuzzy method that considers both of them can improve the mean waiting time, but it is similar to the other algorithms with a long waiting time generating number.

This results from the fact that the fixed rule base cannot satisfy both Up-peak and Down-peak traffic conditions.

As seen in the graph in Fig. 12, Down-peak is superior to the other algorithms in the mean waiting time, but Up-peak is inferior. If we made a rule base which pointed to the minimum long waiting time, which was excellent in Up-peak, the result could be the opposite.

For the above traffic situations, the fuzzy controller has its weak points. But the proposed adaptive dual fuzzy algorithm performs better, if we change the rule base in real time according to the traffic situation. The results of this are given in Table 8.

In the table, we can notice that if we reduce the long-waiting time by four times, the mean-waiting time improves by about 10~30%.

As seen in Tables 9 and 10, the waiting times improve both during Up-peak and during Down-peak.

Table. 8 shows the generation number of long

Table 9 The generation number of long waiting during up-peak traffic(experiment)

	Above 100s	Above 80s	Above 60s	Total
Minimum waiting time method	0	2	6	8
Minimum mean waiting time method	0	2	1	3
Minimum long waiting time method	1	0	1	2
Fuzzy method	0	0	1	1
Adaptive Dual Fuzzy method	0	0	0	0

Table 10 The generation number of long waiting during down-peak traffic(experiment)

	Above 100s	Above 80s	Above 60s	Total
Minimum waiting time method	1	4	7	12
Minimum mean waiting time method	0	1	3	4
Minimum long waiting time method	0	0	4	4
Fuzzy method	0	1	4	5
Adaptive Dual Fuzzy method	0	0	3	3

waits during Down-peak traffic.

The adaptive dual fuzzy algorithm reduces the waiting time and the generation number of long waiting.

The results of the experiments are different to the simulation results under the same conditions. The reason for this is that the distance between each floor, and the motor speed of each elevator was the same as in the simulation, but the distance between each floor was different in the experiment.

In an actual building, there are uncertain elements because hall calls and car calls are not fixed, and the stop-time on a floor is different depending on the user. It is impossible to expect any improvement on these uncertainties. But we are sure that the proposed adaptive dual fuzzy algorithm is superior to other algorithms. And we

are also sure that it has strong points with respect to the convenience of users and for effective operation.

7. Conclusions

In this paper, we carried out the following studies on the efficiency of elevator operation, and improved the elevator group control logic for the convenience of users.

(1) We proposed the adaptive dual fuzzy controller to satisfy the various control goals, and to solve the problems of adapting to changes in traffic patterns.

(2) We proposed new methods which analyze both the recognition of a traffic pattern and a hall call at the same time to find out the present real-time traffic conditions.

(3) We were able to reduce the generating number of long waiting times that appear by generating car calls by allocating hall calls, the accumulation allocation of a new hall call, and the uncertain action of passengers by introducing a reassignment algorithm with reference to real time and efficiency.

(4) We were able to compare and analyze the performance of the proposed group controller with the previous group controller by using an experiment device which works similarly to a real elevator.

References

- Alani, F. A., Mehta, P., Stonham, J., and Prowse, R., 1995, "Performance Optimisation of Knowledge-based Elevator Group Supervisory Control System," *Elevator Technology 6, IAEE*, pp. 114~121.
- Amano, M., Yamajaki, M., and Ikejima, H., 1995, "The Latest Elevator Group Supervisory Control System," *Elevator Technology 6, IAEE*, pp. 88~95.
- Bum, K. C. and Bac, Y. L., 1995, "A Fuzzy Approach to Elevator Group Control System" *IEEE Trans. on System. Man. and Cybernetics*, Vol. 25, No. 6.
- Chan, L. W. and So, A. T. P., 1995, "Dynamic Zoning in Elevator Traffic Control," *Elevator Technology 6, IAEE*, pp. 132~140.
- Chan, L. W. and So, A. T. P., 1997, "Comprehensive Dynamic Zoning Algorithms," *Elevator World*, pp. 99~109.
- Cho, Y. C., Gagov, Z., and Kwon, W. H., 1999, "Elevator Group Control with Accurate Estimation of Hall Call Waiting Times" *Proceedings of the IEEE International Conference on Robotics & Automation*, Detroit, Michigan., Vol. 1, pp. 447~452.
- Gudwin, R., Gomide, F., and Andrade Netto, M., 1998, "A Fuzzy Elevator Group Controller with Linear Context Adaptation," *Proceedings of the IEEE International Conference on Fuzzy Systems*, Vol. 1, pp. 481~486.
- Kaneko, M., Ishikawa, T., and Sogawa, Y., 1998, "Supervisory Control for Elevator Group by Using Fuzzy Expert System," *Proceedings of the 23rd IECON Control and Instrumentation*, Vol. 1, pp. 370~376.
- Kim, C. B., Seong, K. A., Kwang, H. L., and Kim, J. O., 1998, "Design and Implementation of a Fuzzy Elevator Group Control System," *IEEE Transaction on Systems, Man and Cybernetics, Part A*, Vol. 28, Issue. 3, pp. 277~287.
- Pepyne, D. L. and Cassandras, C. G., 1996, "Optimal Dispatching Control For Elevator Systems During Uppeak traffic," *Proceedings of the 35th IEEE Decision and Control*, Vol. 4, pp. 3837~3842.
- Pepyne, D. L. and Cassandras, C. G., 1997, "Adaptive Dispatching Control For Elevator Systems During Uppeak traffic," *Proceeding of the 36th IEEE Decision and Control*, Vol. 1, pp. 680~685.
- Pepyne, D. L. and Cassandras, C. G., 1998, "Optimal Dispatching Control For Elevator Systems During Uppeak traffic," *IEEE Transaction on Control Systems Technology*, Vol. 5, Issue. 6, pp. 629~643.
- Powell, A. B., 1992, "Important Issues in Up-peak Traffic Handling," *Elevator Technology 4, IAEE*, pp. 207~218.
- So, A. T. P., Beebe, J. R., Chan, L. W., and Liu, K. S., 1995, "Elevator Traffic Pattern Recognition by Artificial Neural Network," *Elevator Tec*

hnology 6, IAEE, pp. 122~131.

So, A. T. P., Yu, J. K. L., and Chan, W. L., 1999, "Dynamic Zoning Based Supervisory Control for Elevators," *Proceedings of the IEEE International Conference on Control Applications*, Kohala Coast-Island of Hawai'i, U. S. A., Vol. 2, pp. 1591~1596.

Tobita, T., Fujino, A., Inaba, H., Yoneda, K., and Ueshinma, T., 1991, "Elevator Characterized Group Supervisory System," *IECON*, pp. 1972

~1976.

Umeda, Y., Uetani, K., Ujihara, H., and Tsuji, S., 1989, "Fuzzy Theory and Intelligent Options," *Elevator World*.

Zhu, D., Li, J., Zhou, Y., Guanghui, S., and Kai, H., 1997, "Modern Elevator Group Supervisory Control System and Neural Networks Technique," *IEEE International Conference on Intelligent Proceeding System*, Vol. 1, pp. 528~532.